

Key Features:



Certified bear resistant, by USDA (United States Forest Service) and IGBC

- Bear safe ABS laminated Baltic birch plywood panels
- Marine-grade aluminum panels engineered for impact resistance and rigidity
- Compact and light weight, for ease of handling
- Free standing, stabile setup with use of optional legs
- Front door panel doubles as work surface
- Balanced interior layout will complement most staple food package sizes
- Large spice drawer
- Pad lockable bear safe lock
- Integrated rigging points for wall mount or pack saddle utility
- Multiple systems configurations with optional accessories
- Life time product

Applications:

- Pack Outfitter
- White Water Rafting
- Overland travel
- Expedition, Safari
- Work camp
- Emergency kitchen
- Outdoor Catering
- ... and anytime you need to take your kitchen outdoors

The Field Pantry is a container for storage of staple food items and supplies. Together with the Field Kitchen and the Ice box it is an essential part of a complete and bear safe outdoor kitchen system.

It is made of deep drawn marine-quality aluminum panels for light weight and high impact strength. ABS-laminated Baltic birch plywood panels provide desired exterior protection, while the clear

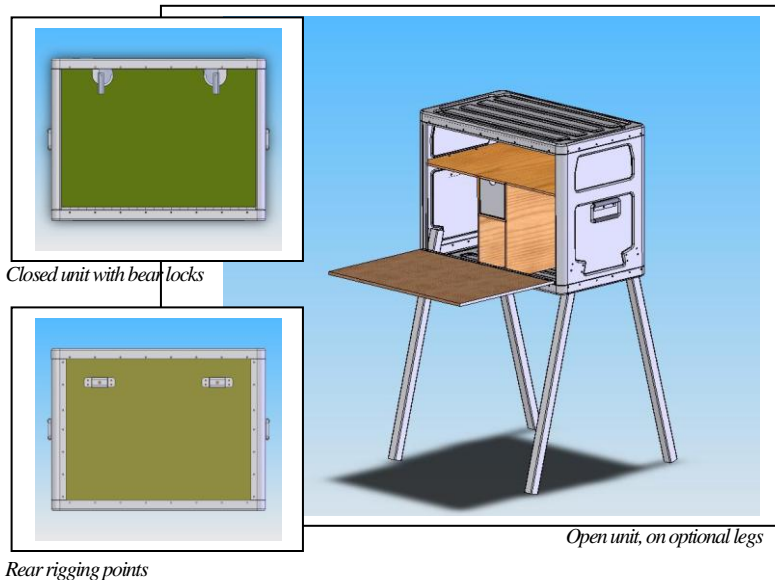

Rear rigging points

Open unit, on optional legs

coated Birch plywood interior gives it a unique look and feel, fitting the outdoors. When put on its optional legs it becomes a free standing unit.

The spice drawer, shelves and dividers for storing the food items and supplies are dimensioned to fit most commercially available items.

Specifications:

Outside Dimensions (H x W x D)	19.4 in x 25.4 in x 15.00 in (492 mm x 645 mm x 381 mm)
Inside Dimensions of spice ware drawer (H x W x D)	4.4 in x 4.4 in x 13.9 in (112 mm x 112 mm x 353 mm)
Maximum group size	8
Weight (empty)	27 lbs (13 kg)
Table top height (on long leg set)	26 in (660 mm)
Counter top height (long leg ; short leg set)	43 in (109 mm); 37 in (940 mm)
Transport	One foldable sprung handle on each side with rubber grip.
Material	Baltic birch plywood riveted to marine grade aluminum panels
Finish	Polyurethane clear coat on wood panels inside and olive colored ABS lamination on the outside
Shipping Dimensions	20.0 in x 26.5 in x 15.8 in (508 mm x 673 mm x 401 mm)

Field Pantry P120

For available configurations, accessories and system setups visit www.kanzoutdoors.com

Dimensions:

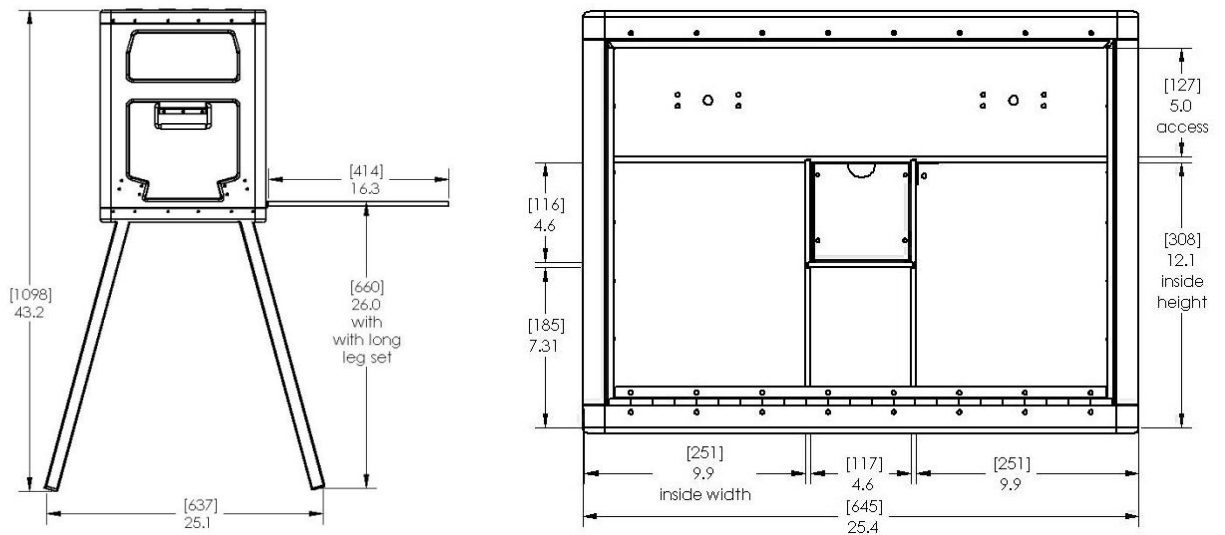

Side view with optional long leg set (subtract [152 mm] 6.0 inches in height for short leg set)



KANZ OUTDOORS LLC
P.O. Box 280388
Northridge, CA 91328-0388
P: 818 894 6589
F: 818 698 6529

WWW.KANZOUTDOORS.COM

A3 SS PT09/10